

9 1		

(United Nations)
(International Air Transport Association, IATA)

International Airline = IATA

Transport Association

A, B

: A _____

B

United Nations Number= UN 2814

9 2		

UN 2900

A

B

:B

United Nations Number= *UN 3373*

بسته بندی نمونه ها

()

Cold Box

UN) B

(UN 2814, UN2900) A

(3373

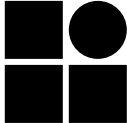
9 3		



:

()

()

UN

:(Proper shipping name)

UN2814

INFECTIOUS SUBSTANCE AFFECTING HUMANS

INFECTIOUS SUBSTANCE UN 2900

() . AFFECTING ANIMALS only

Diagnostic Specimens Clinical Specimens UN3373

UN 2814“INFECTIOUS SUBSTANCE AFFECTING HUMANS”

UN 2900“INFECTIOUS SUBSTANCE AFFECTING ANIMALS”

()

() . " "

9 4		

(Ice Pack)

Package Orientation

()



UN 2814



9 5		

Packaging instructions for UN 2900 and UN 2814: category A

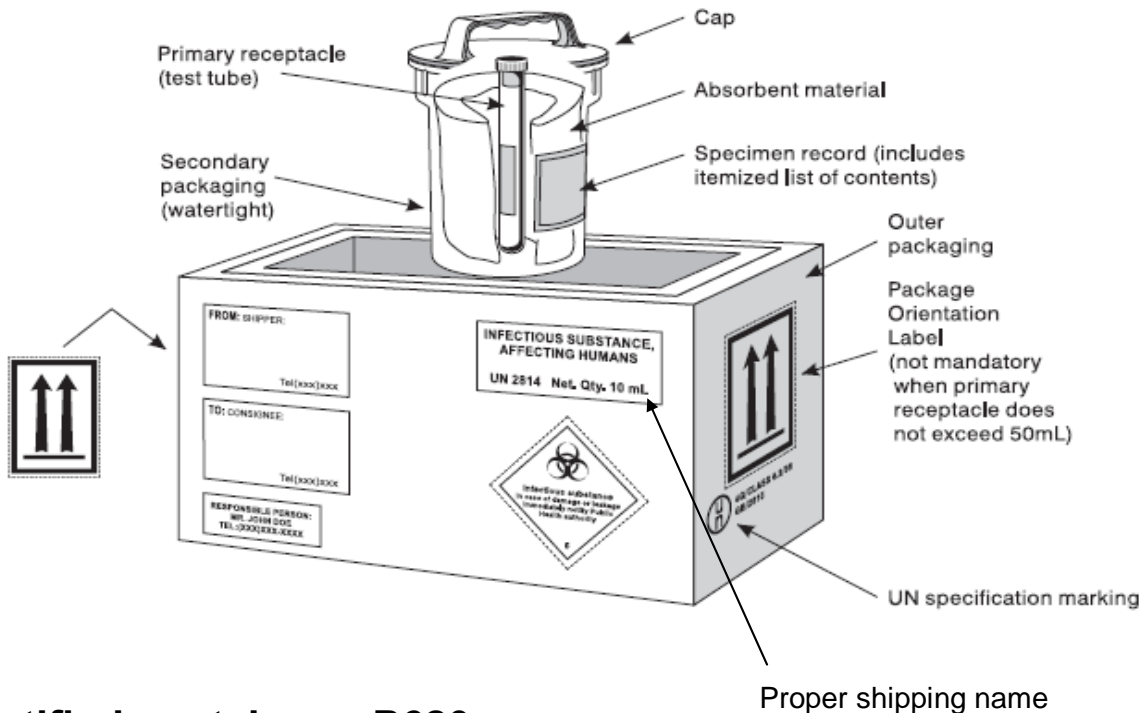

UN certified containers, P620

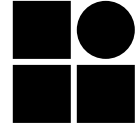

Packaging for UN 3373 (category B, P650)

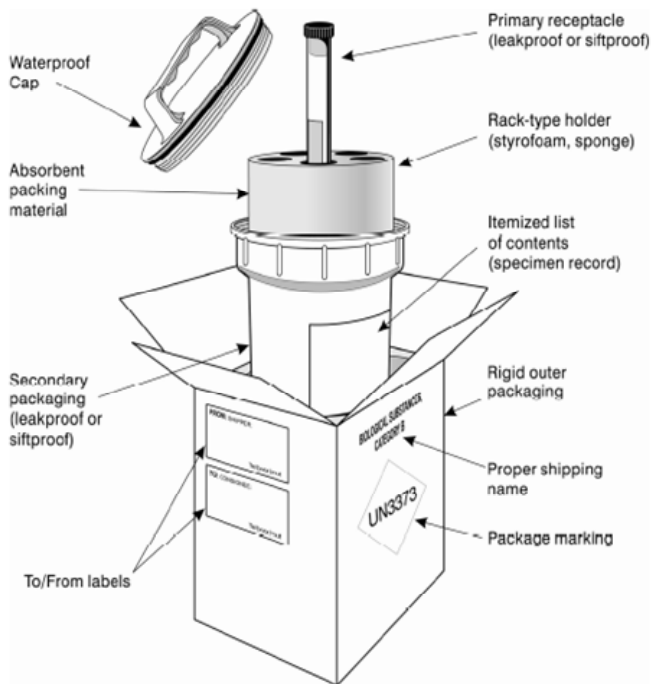

Primary receptacle:

- Leakproof or stiftproof
- absorbent material (eg. Kleenex)

Secondary packaging:

- Leakproof or stiftproof

Rigid outer packaging:

Never envelopes

9 7		

Figure 7.2.A
Class 6 — Infectious Substances (Division 6.2)



The lower part of the label should bear the inscription:

INFECTIOUS SUBSTANCE
In case of Damage or Leakage
Immediately Notify
Public Health
Authority

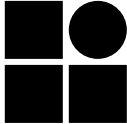
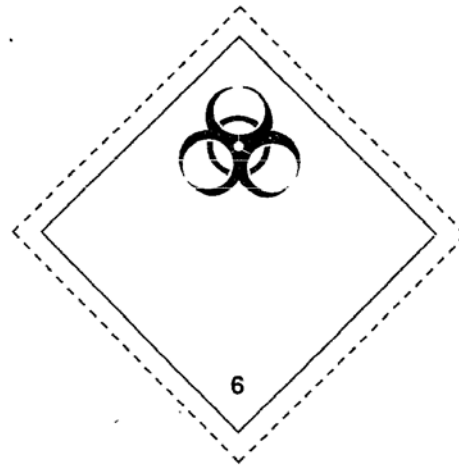
Name: Infectious Substance
Minimum dimensions: 100 × 100 mm

For small packages the dimensions may be 50 × 50 mm
Symbol (three crescents superimposed on a circle) and inscription:
Black
Background: White

9 8		

**Figure 7.2.F
Package Orientation**

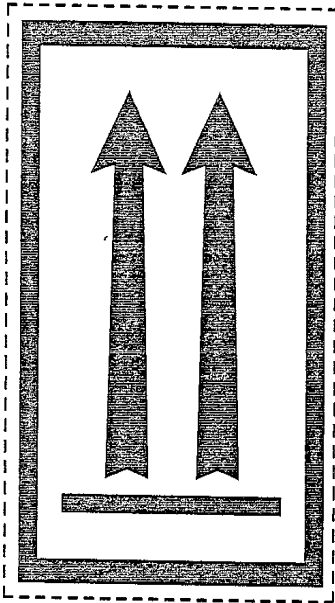

**Name: Package Orientation (This Way Up)
Minimum dimensions: 74 × 105 mm
Colour: Red or Black on a contrasting background**

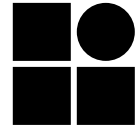

**Transportation packagings for
Class 6.2 Infectious Substances
according to ICAO-TI and IATA/DGR
Packinginstructions 602 and 650**

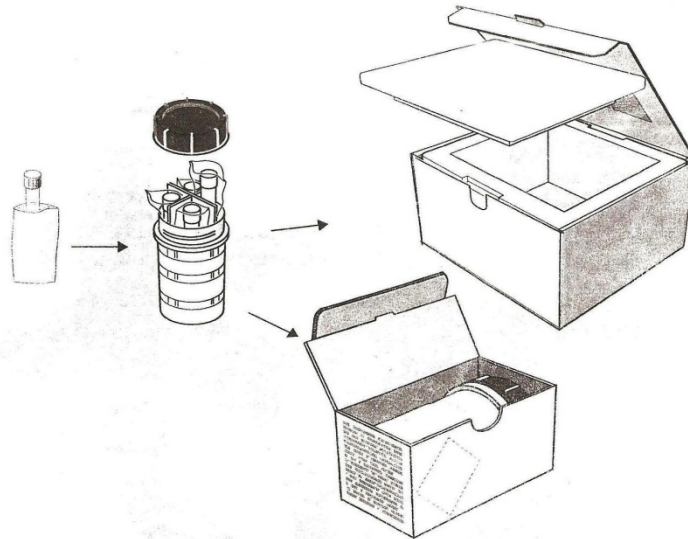

Noax Sys AB
PO Box 2022, SE-18202 Stockholm-Danderyd Sweden
Phone +46 8753 46 80 Fax +46 8753 06 70
Mail address: mail@noax.se
WWW.noaxsys.se